

# World-leading R&D in Industrial Automation, IoT and AI.

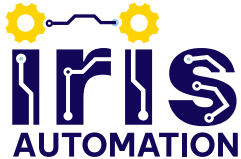

[www.iris-auto.com](http://www.iris-auto.com)



## About IRIS.

Our systems enable the rapid, accurate and easy inspection of production lines and perform several industrial inspection tasks:

- Defect Detection
- Object Detection
- Measurement Tool
- Optical Character Recognition

## Worldwide Manufacturing

We support industries around the globe to automate and optimize production lines.

IRIS Automation aims to revolutionize the industrial inspection process and support businesses to:

-  Increase production output
-  Minimize errors and defects
-  Enhance product quality
-  Reduce production costs

IRIS also offers comprehensive AI and IoT solutions, PCB prototyping, and advanced Large Language Model services.

## Best Quality

- Human like intelligence
- Robust design
- Self-learning capacity

# Defect Detection

Identifying imperfections, ensuring products meet the highest quality standards. With sophisticated image analysis, even the most minute discrepancies are detected, reducing waste and enhancing product integrity.

INPUT IMAGE

OUTPUT IMAGE

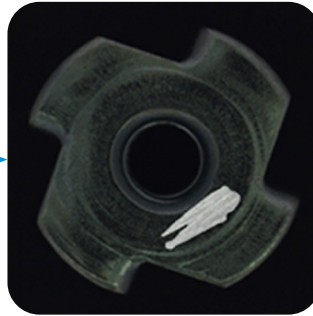
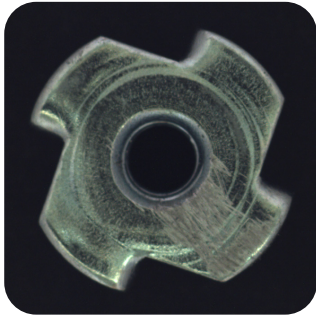

- Increase their production output
- Enhance their product quality
- Minimize errors and defects

# Object Detection

Recognizing and tracking various items in real-time, regardless of the complexity of the production line. This function ensures accurate sorting, counting, and control in high-paced manufacturing environments.

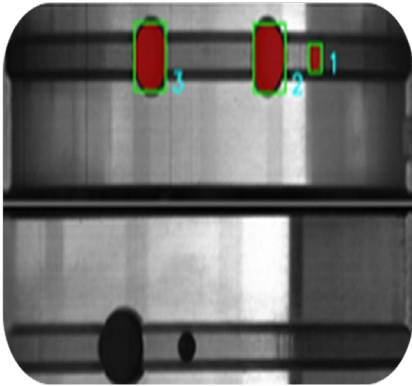

- Detecting, localizing, and categorizing various objects
- Effective across different scales
- Simultaneous multi-object recognition

# Measurement Tool

Quantifying dimensions to the finest degree with our AI technologies. This feature guarantees that all parts and products fit perfectly to precise design specifications.

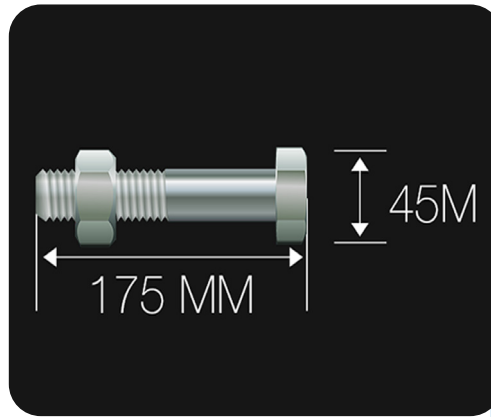
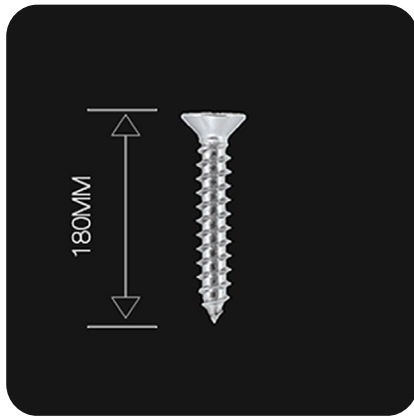

- Precise measurement of height, radius, and width
- Quality control in product manufacturing
- Accurate conformity to product specifications

# OCR

Transforming visual data into actionable text, enabling seamless data capture, traceability, and streamlined inventory management. An essential tool for modern industries requiring precise label and character verification.

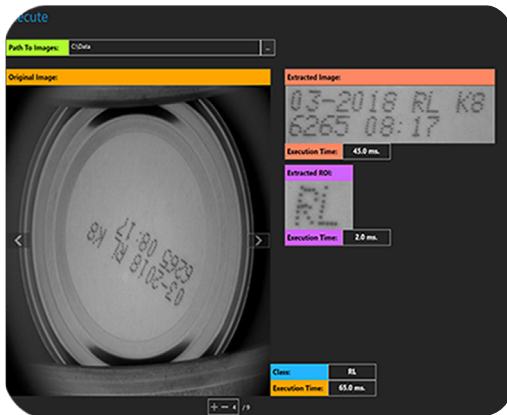

- Intelligent multimodal data analysis
- Context and semantics extraction from visual data
- Image conversion to actionable, context-rich text

# Technological Innovation Consultation & Services

Leading the way in tech innovation, IRIS offers an array of AI and IoT services, PCB prototyping, and custom Large Language Model applications. Our solutions are crafted to revolutionize business operations, driving efficiency and competitive advantage in a rapidly evolving global market.

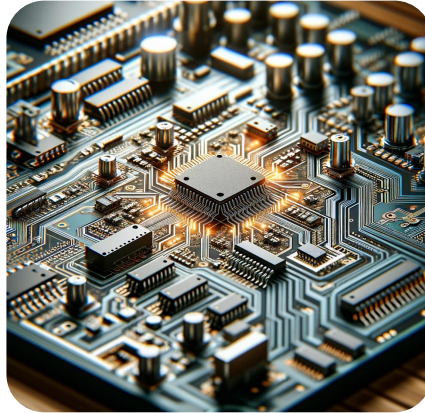

- Design and integration of bespoke AI and IoT solutions
- Expert PCB prototyping services
- Advanced Large Language Model applications

# Contact Us

Contact us at IRIS to discover how we can drive transformation in your business.

Techno Centre,  
Puma Way,  
Coventry, CV1 2TT, UK  
T: +44 7894329501



Dubai Silicon Oasis,  
Integrated Economic Zones,  
Dubai, UAE  
T: +971 588856091



[www.iris-auto.com](http://www.iris-auto.com)

© Iris Automation copyright 2024. Any enquiries regarding this document/publication should be e-mailed to us at: [info@iris-auto.com](mailto:info@iris-auto.com)